

FSR-C25 Combination Foldable Studreel Instruction Manual



Table of Contents

Parts List.....	3
Assembly.....	5
Making Adjustments.....	9

Parts List

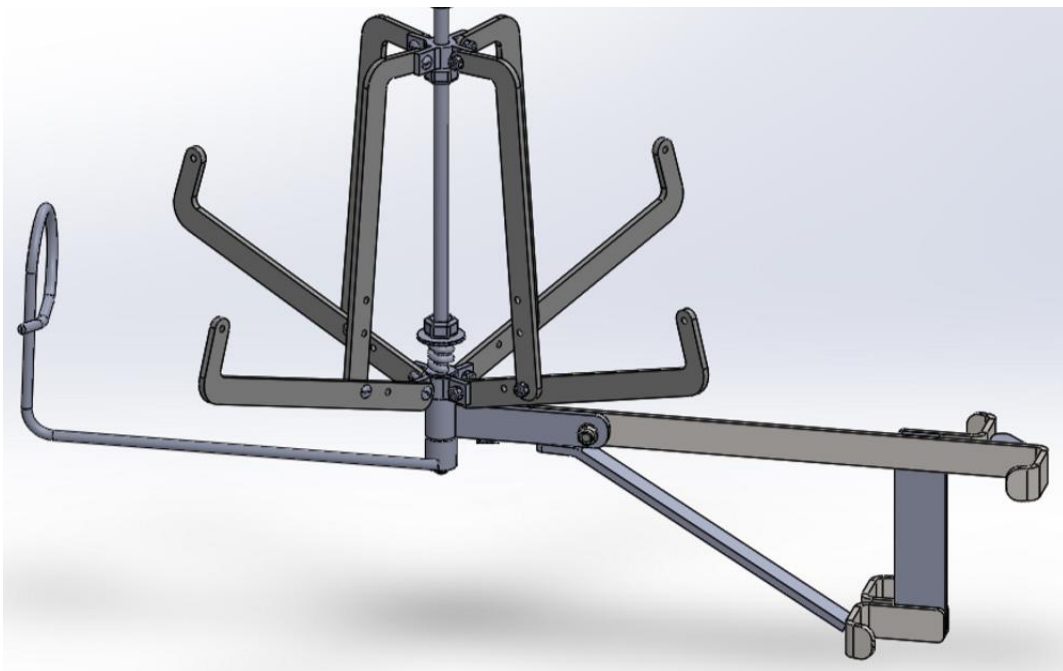
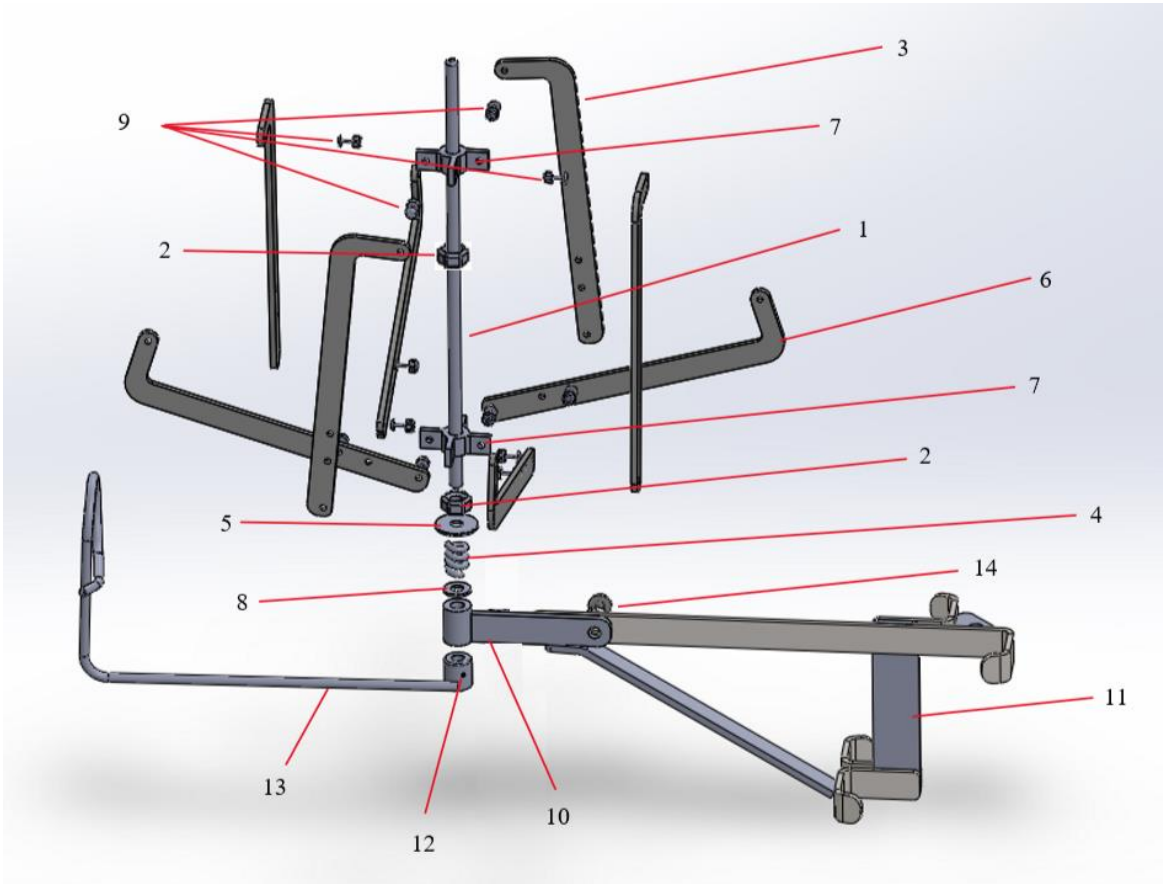

Part Number	Part Name	Quantity
1	Spindle Rod FSR-100	1
2	Hex Set-Screw Bushing FSR-101-A	2
3	Wire Hub Arm FSR-102	4
4	Spring FSR-103	1
5	Wire Tray Arm Stop Washer FSR-104	1
6	Wire Tray Arm FSR-105	4
7	Star Hub FSR-106-B	2
8	Small Washer FSR-108	1
9	Arms Assembly Nut & Screw FSR-109	12
10	Swivel Mount Assembly Weldment FSR-110	1
11	Stud Mount Assembly Weldment FSR-112	1
12	Wire Guide Set-Screw FSR-115	1
13	Wire Guide FSR-116	1
14	5/16" Bolt, Washers & Nut FSR-117	1

Assembly

Assembly of Arms Assembly

To assemble the wire hub and attach the wire tray arms (FSR-105), the wire hub arms (FSR-102) have to be attached to the star hub (FSR-106-B) using an arms assembly nut & screw (FSR-109) as shown in figure 1. Each wire hub arm should also be attached to one of the hub mount holes on the corresponding wire tray arm once again using an arms assembly nut & screw. Finally, the wire tray arms should be attached to a second star hub.

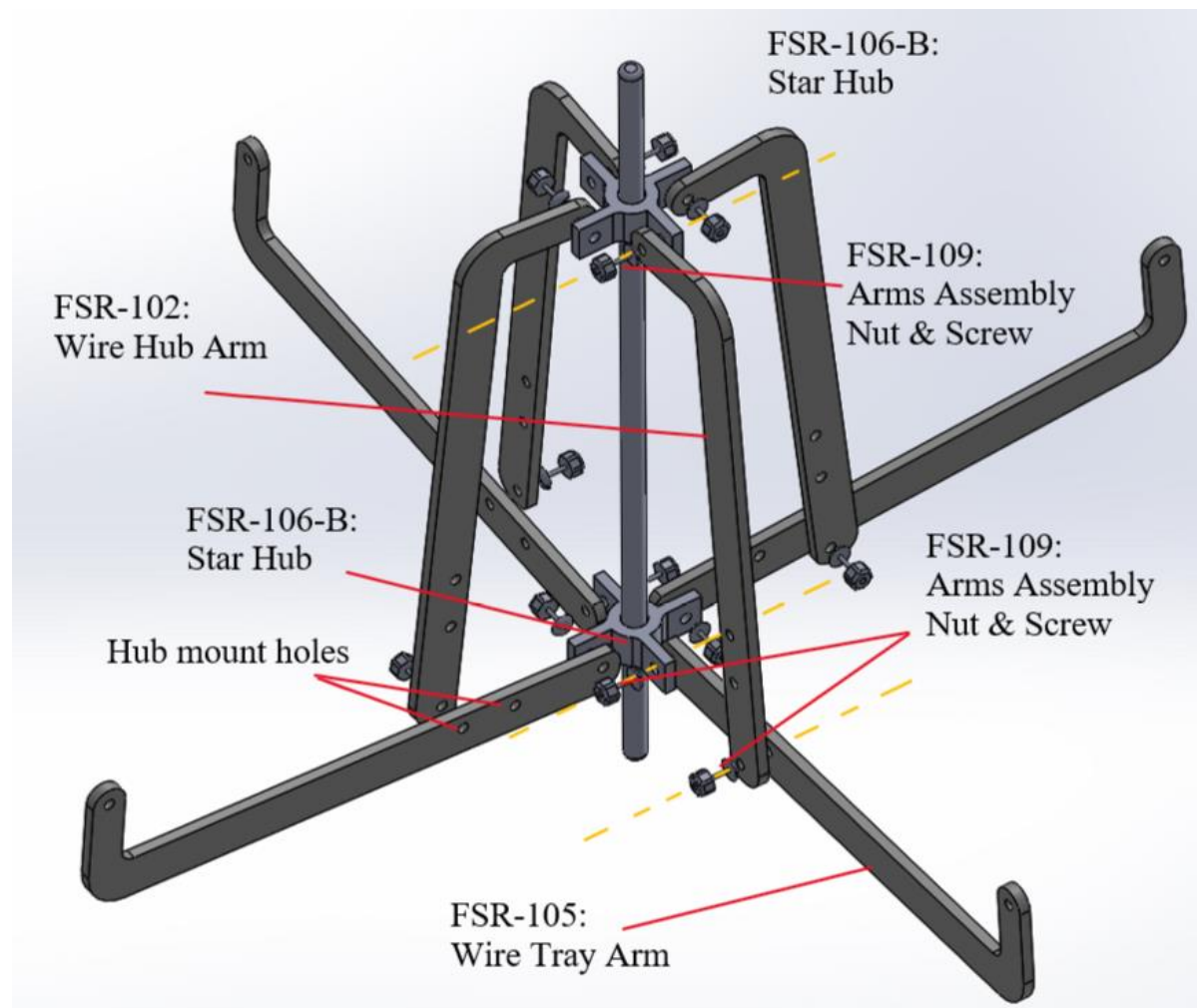

Figure 1
Assembly of Arms Assembly.

To finish assembling the arms assembly, the rest of the assembly has to slide onto the spindle rod (FSR-100). First, the set-screws in the hex set-screw bushings (FSR-101-A) have to be loosened so that they can slide onto the spindle rod. Next the swivel mount assembly weldment should be slid onto the bottom of the spindle rod. Then the two hex set-screw bushings, the wire tray arm stop washer (FSR-104), the spring (FSR-103), and the small washer (FSR-108) should be slid onto the spindle rod between the two star hubs as shown in figure 2.

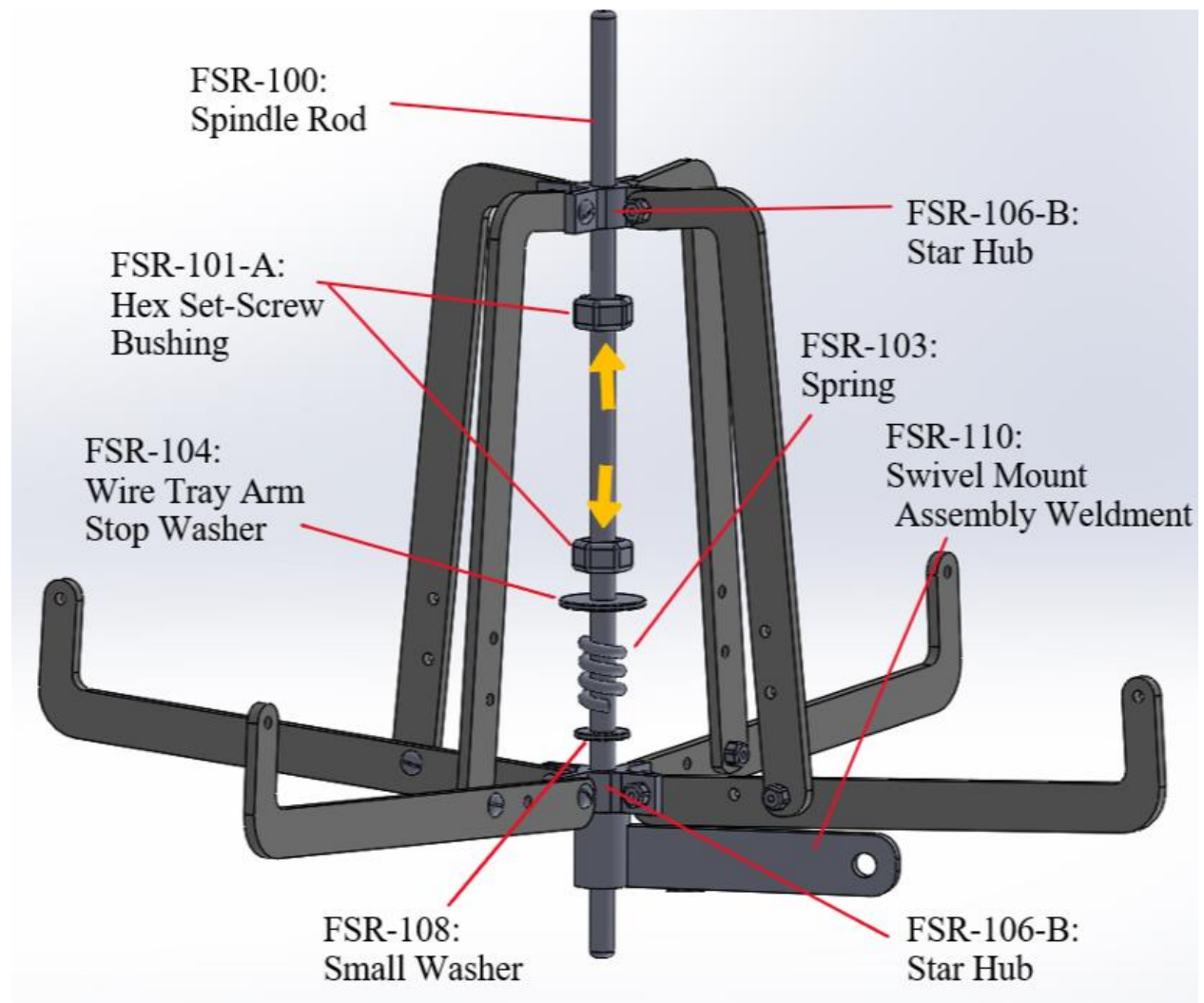

Figure 2

The parts of the arms assembly should be stacked on the spindle rod in the order shown above.

Underneath the swivel mount assembly weldment, the wire guide (FSR-116) should be slid onto the spindle rod, seen in figure 3. To finish assembly, the set-screws in the wire guide and hex set-screw bushings should be tightened to raise the wire tray arms to the preferred angle. When this is achieved, the top hex set-screw bushing should be snug with the top star hub, and the bottom bushing, stop washer, spring and small washer should securely rest on the bottom star hub. Instructions on adjusting the angle of the wire tray arms can be found on pages 9-10

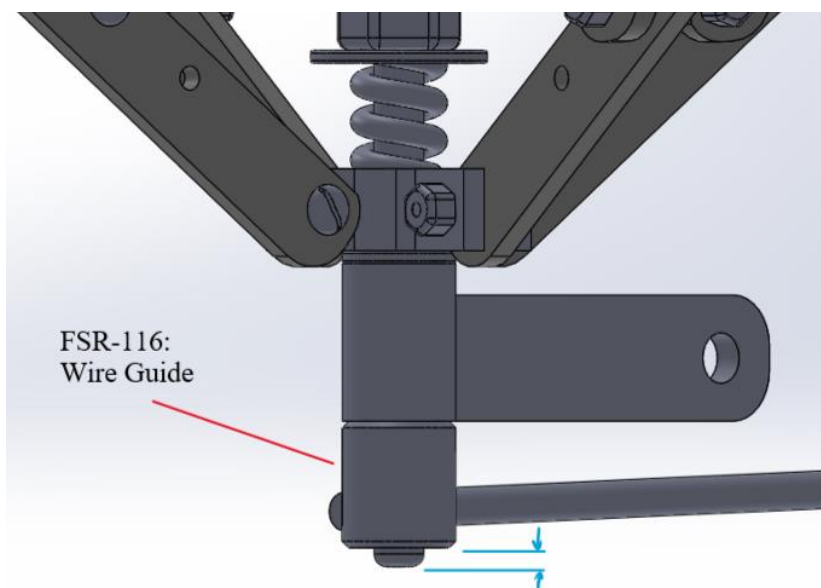

Figure 3

With the wire guide underneath the swivel mount assembly weldment, the spindle rod should not protrude very far from the bottom of the wire guide.

Mounting the Arms Assembly to the Stud Mount Assembly Weldment

Next, the arms assembly can be attached to the stud mount assembly weldment. This is done by using the 5/16" bolt, washers & nut to fasten the swivel mount assembly weldment to the stud mount assembly weldment as seen below in figure 4.

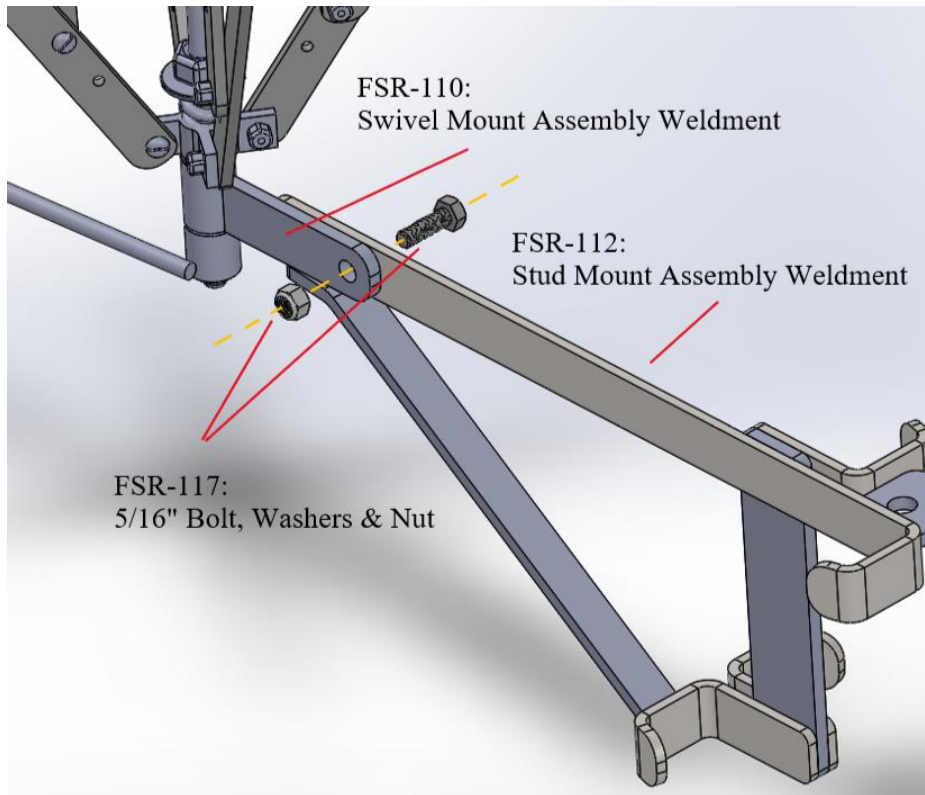

Figure 4

The 5/16" Bolt is used to attach the stud mount assembly weldment and the swivel mount assembly weldment together.

Mounting to a Stud

Now that everything is assembled, it can be mounted to a 2x4 or 2x6 stud. One side of the stud mount assembly weldment (FSR-112) has hooks for mounting a 2x6 and the opposite side is for a 2x4. Either way the procedure is the same. Tilt the stud mount assembly at about a 30° angle as seen in figure 5. Fit the hooks around the stud and rotate the stud mount so that the crossbar is level.

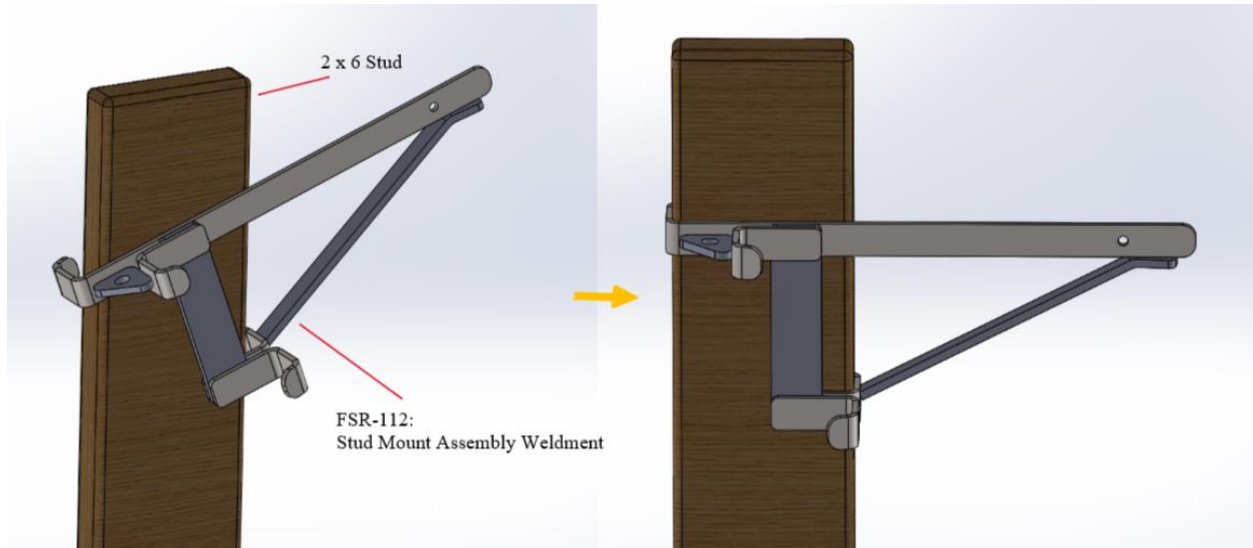

Figure 5
Mounting the assembly is easy. In this case the stud mount is being used for a 2x6 stud, but the two closest can be used for a 2x4.

The FSR-C-25 Combination Foldable Studreel is now fully assembled. The next section will help you if you would like to make some adjustments.

Making Adjustments

Raising or Lowering the Wire Tray Arms

To raise or lower the wire tray arms (FSR-105) the user must first unscrew the set screw in the screw bushing (FSR-101-A) labelled in figure 1 until loose. Then the screw bushing can slide up or down the spindle rod (FSR-100) to the satisfactory height, and the set-screw can be tightened again to hold the wire tray arms in the desired position. This process can be seen in figure 6 below.

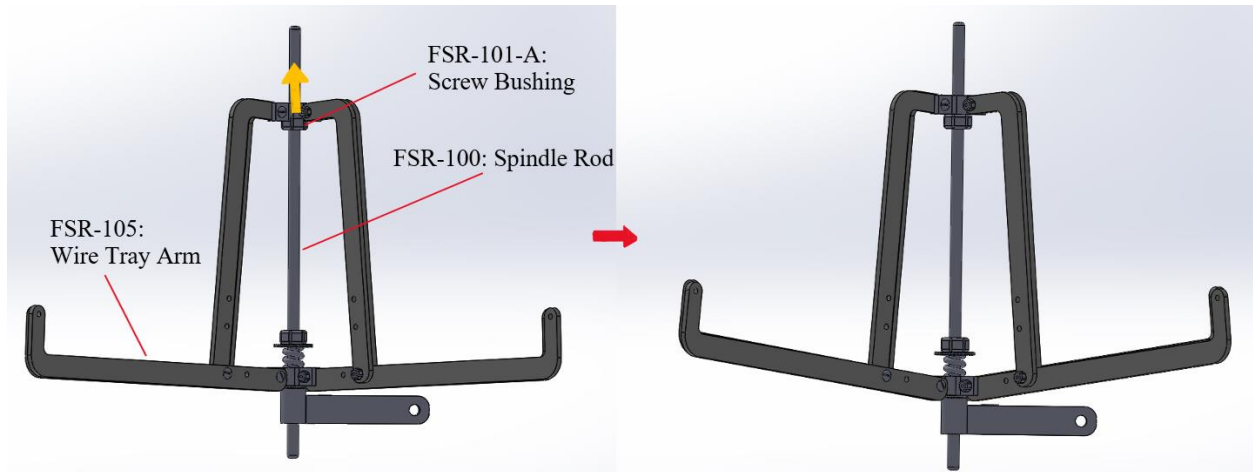

Figure 6
Screw bushing is slid up the spindle rod to raise the wire tray arms, or slid down to lower the arms.

Adjusting Wire Tray Hub Diameter

Sometimes it is necessary to adjust the diameter of the wire tray hub diameter to accommodate a different sized spool or wire. To do this, the arms assembly nuts & screws (FSR-109) that connect the wire tray arms (FSR-105) to the wire hub arms (FSR-102) must be unscrewed and removed. The wire hub arms can then be attached to the wire tray arms using an alternative mounting hole at the base of the wire tray arms. This process is illustrated in figure 7 below.

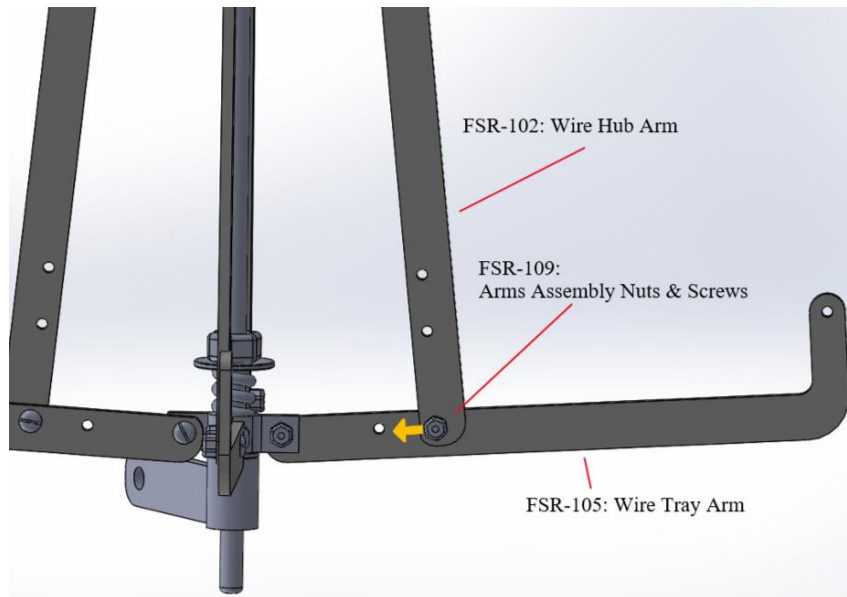

Figure 7

Wire hub arms can be reattached at an alternate mounting hole in the wire tray arms to accommodate different spool.

Note: only the two holes in the wire tray arms shown in figure 8 are meant to be used to mount to the wire hub arms.

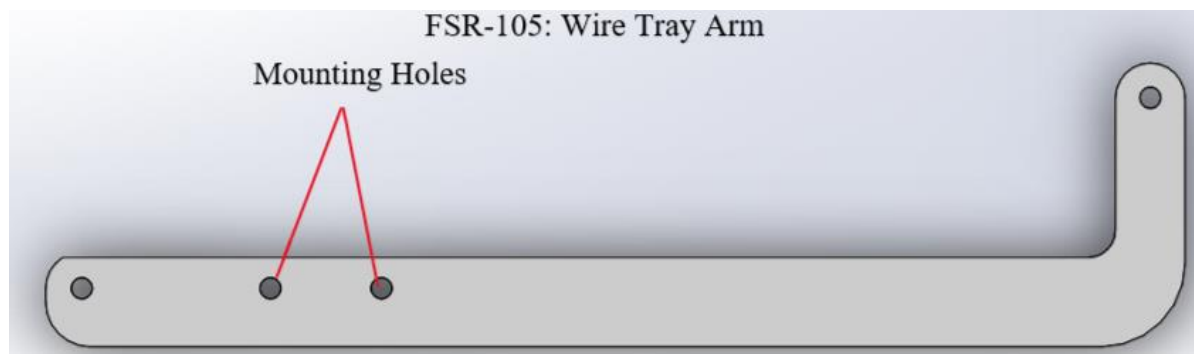

Figure 8

Mounting holes in wire tray arm form wire hub arm